

PT100MF1MP1

Phototransistor



■ Features

1. Mountable by both top view and side view SMD package
2. Plastic mold with resin lens
3. Sensitive (Darlington phototransistor)
4. Mold with visible light cut resin
5. Lead free and RoHS directive component

■ Agency Approvals/Compliance

1. Compliant with RoHS directive (2002/95/EC)
2. Content information about the six substances specified in “Management Methods for Control of Pollution Caused by Electronic Information Products Regulation” (popular name: China RoHS) (Chinese: 电子信息产品污染控制管理办法); refer to page 9

■ Applications

1. Office automation equipment
2. Audio visual equipment
3. Home appliances
4. Telecommunication equipment
5. Measuring equipment
6. Tooling machines
7. Computers

Notice The content of data sheet is subject to change without prior notice.

In the absence of confirmation by device specification sheets, SHARP takes no responsibility for any defects that may occur in equipment using any SHARP devices shown in catalogs, data books, etc. Contact SHARP in order to obtain the latest device specification sheets before using any SHARP device.

Outline Dimensions

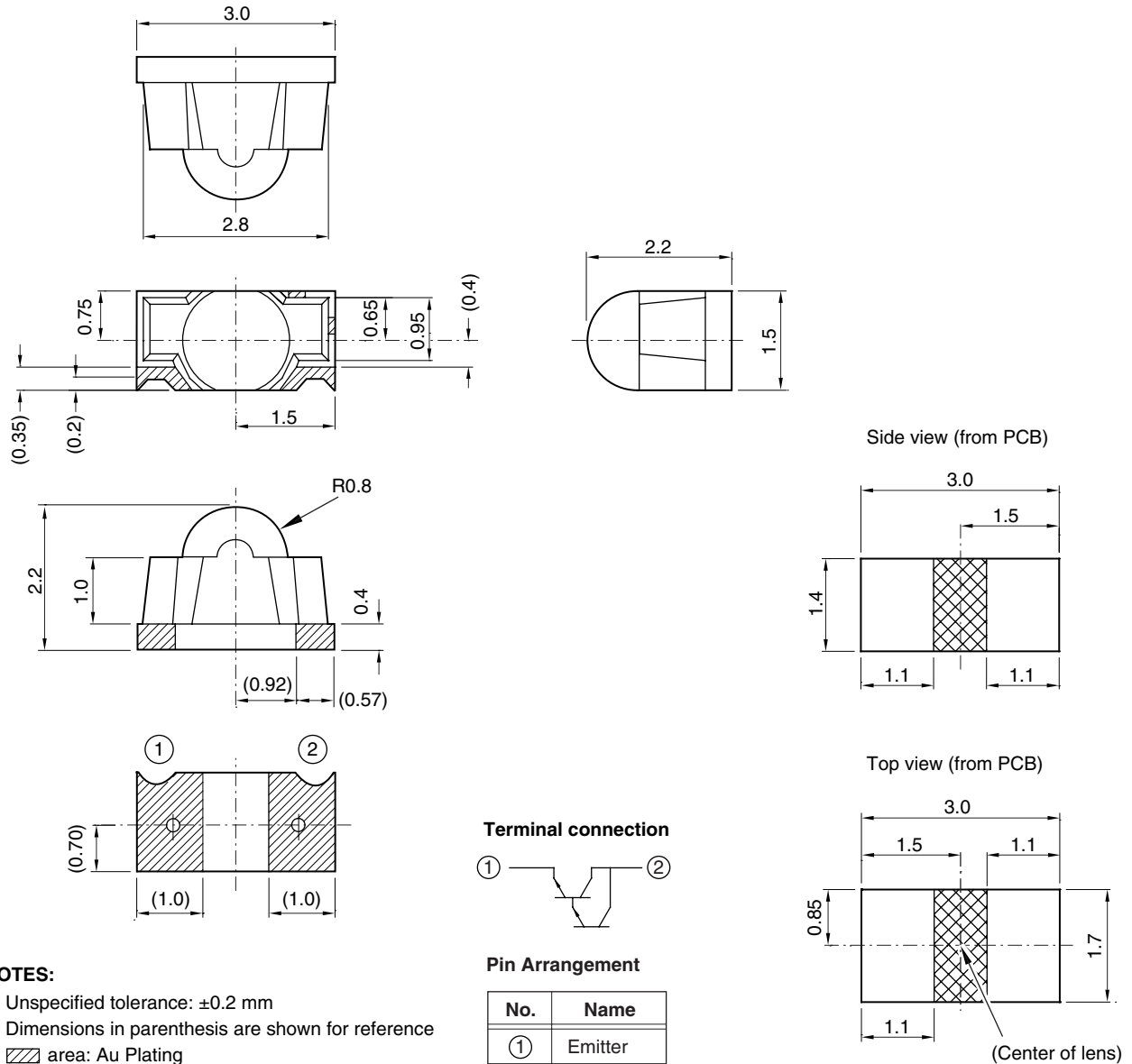

NOTES:

1. Unspecified tolerance: ± 0.2 mm
2. Dimensions in parenthesis are shown for reference
3. area: Au Plating
4. Do not wire in this area
5. Resin burr are not included in outline dimensions
6. Package: Black (Visible light cut-off epoxy resin)
7. Unit: mm

Terminal connection

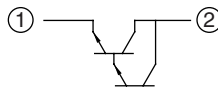

Pin Arrangement

No.	Name
①	Emitter
②	Collector

■ Absolute Maximum Ratings

(Ta = 25°C)

Parameter	Symbol	Rating	Unit
Collector-emitter voltage	V_{CEO}	35	V
Emitter-collector voltage	V_{ECO}	6	V
Collector current	I_C	20	mA
Collector power dissipation	P_C	75	mW
Operating temperature	T_{opr}	-30 to +85	°C
Storage temperature	T_{stg}	-40 to +95	°C
Soldering temperature *1	T_{sol}	240	°C

*1 10 s (MAX.) see reflow profile on page 8.

■ Electro-optical Characteristics

(Ta = 25°C)

Parameter	Symbol	Conditions *1	MIN.	TYP.	MAX.	Unit
Collector current	I_C	$E_e = 0.01 \text{ mW/cm}^2$, $V_{CE} = 5 \text{ V}$	0.2	–	1.2	mA
Dark current	I_{CEO}	$E_e = 0$, $V_{CE} = 10 \text{ V}$	–	–	1.0	μA
Collector-emitter saturation voltage	$V_{CE(sat)}$	$E_e = 1 \text{ mW/cm}^2$, $I_C = 0.8 \text{ mA}$	–	–	1.0	V
Collector-emitter breakdown voltage	BV_{CEO}	$I_C = 0.1 \text{ mA}$, $E_e = 0$	35	–	–	V
Emitter-collector breakdown voltage	BV_{ECO}	$I_E = 0.01 \text{ mA}$, $E_e = 0$	6	–	–	V
Peak sensitivity wavelength	λ_p	–	–	860	–	nm
Response time (Rise)	t_r	$V_{CE} = 2 \text{ V}$, $I_C = 5 \text{ mA}$, $RL = 100 \Omega$	–	400	2,000	μs
Response time (Fall)	t_f		–	300	1,500	μs
Half intensity angle	$\Delta\theta$	–	–	±15	–	°

*1 E_e : Illuminance by CIE standard light source A (tungsten lamp)

Fig. 1 Collector Power Dissipation vs. Ambient Temperature

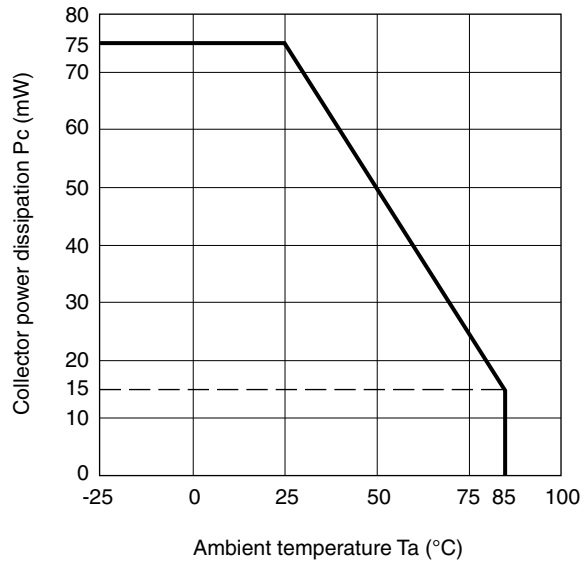

Fig. 3 Radiation Diagram

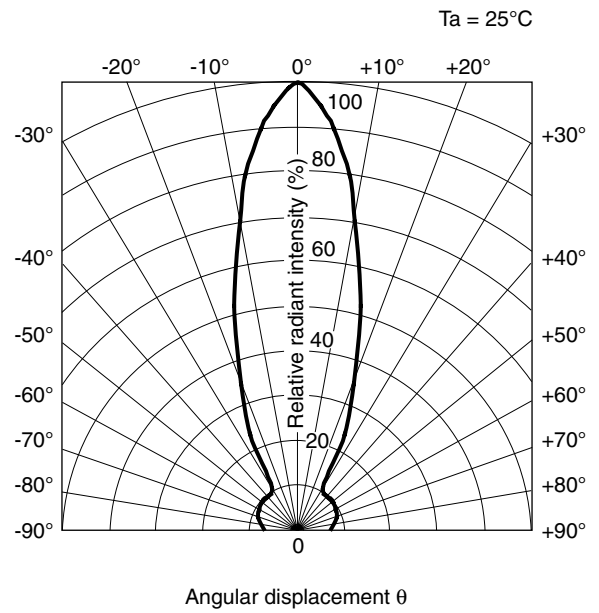
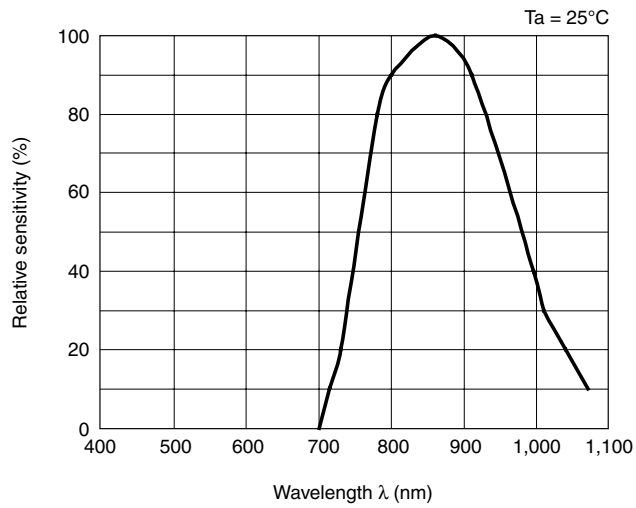

Fig. 2 Spectral Sensitivity



Package Specification

Fig. 4 Tape Shape and Dimension

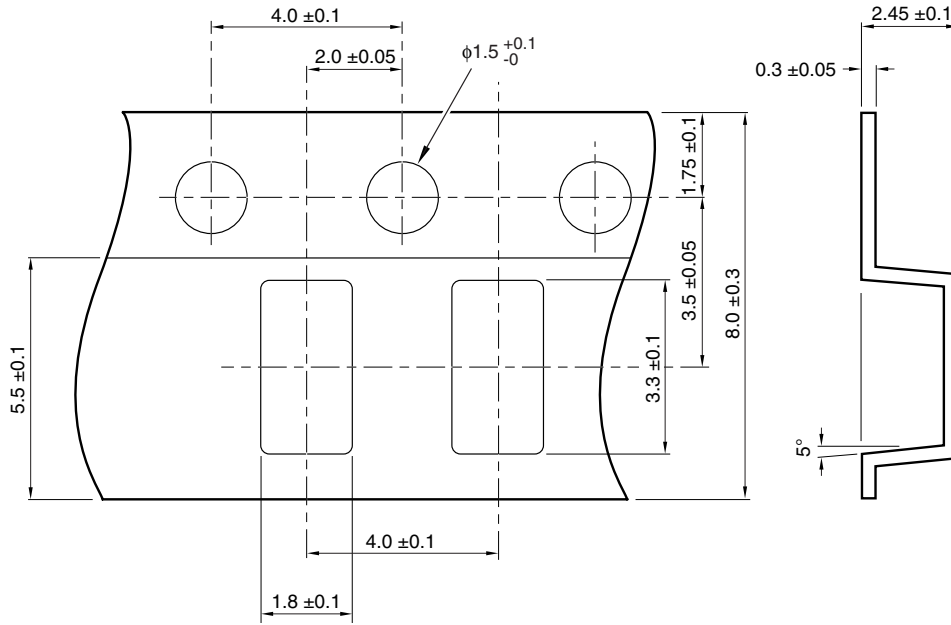
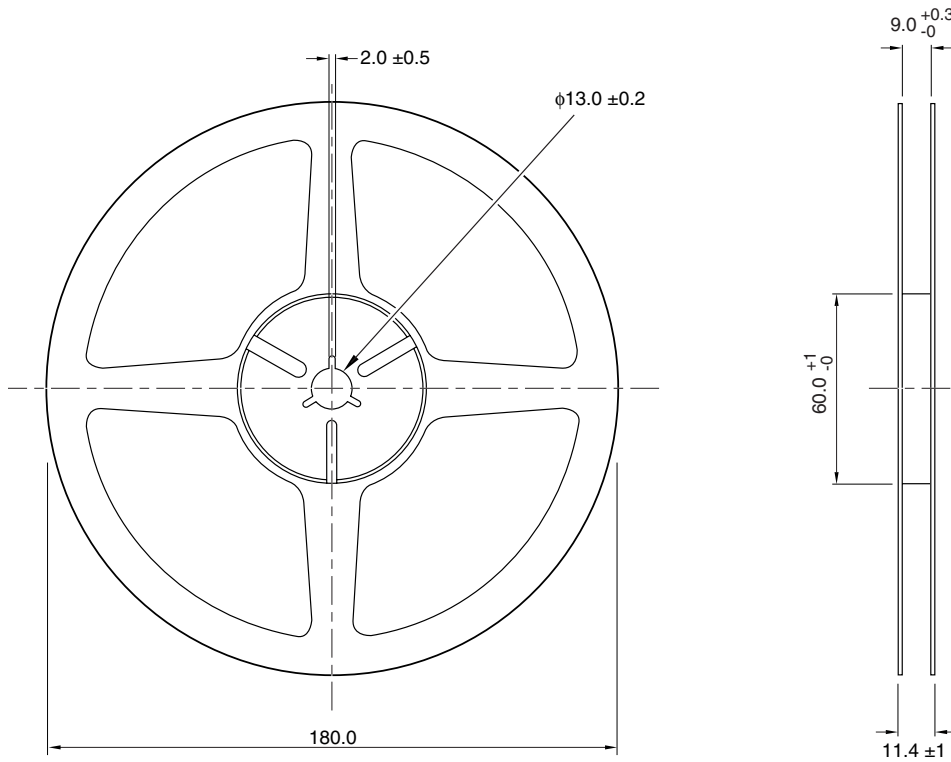
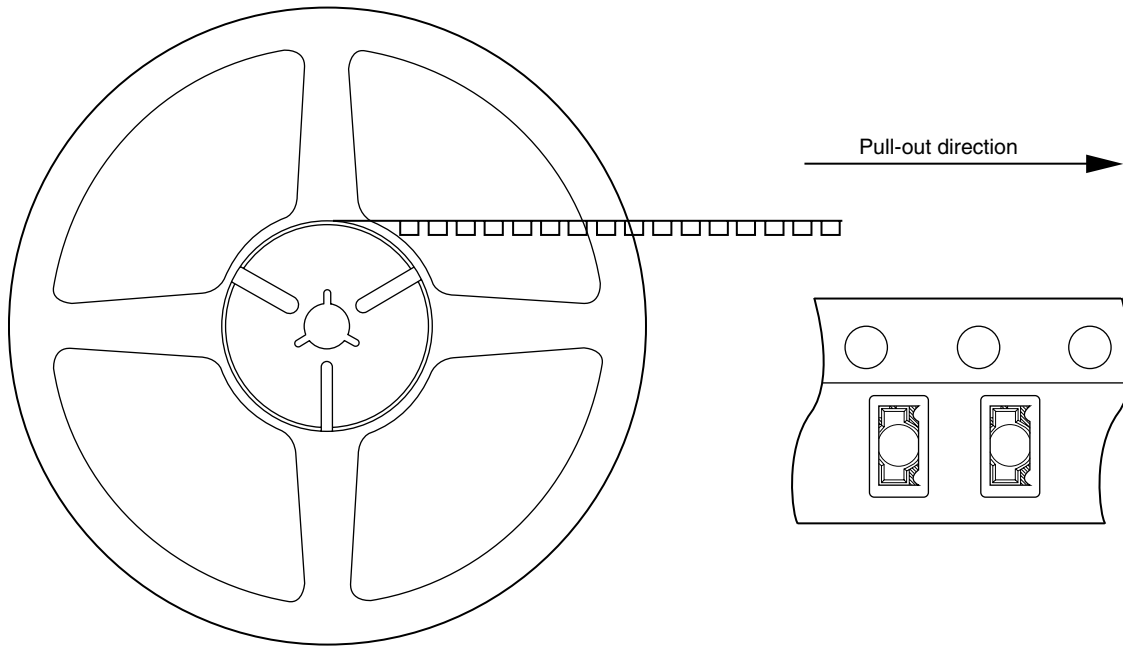

Fig. 5 Reel Shape and Dimension



NOTE: Units are in mm

Fig. 6 Production Insertion Direction



● Taping Specification

1. See Fig. 4 for the tape structure and dimensions. The carrier tape structure incorporates a cover tape thermally bonded to it to protect the parts against electrostatic damage.
2. See Fig. 5 for the Reel structure and dimensional information.
3. See Fig. 6 for the Product Insert Direction. The collector terminal is at the hole side of the tape.

● Packing Specifications

Name	Material	Quantity
Aluminum laminated bag	Aluminum polyethylene	Refer to Packaging Method
Label	Paper (filled in by factory)	–
Humidity indicator card	Paper (filled in by factory)	1 sheet/reel

● Packaging Method

1. Seal the aluminum laminated bag and include the ruled tape-reel and humidity indicator card quantity.
2. Fill in the label and paste on the bag.
3. Put the moisture-proof laminated bag in the ruled case.

Package Shape	Product	Quantity	Moisture-proof Bag Quantity
Tape = reel (φ 180 mm)	1 ch type	1,500 pcs/reel	1 reel/bag

■ Manufacturing Guidelines**● Storage and Handling**

1. Store these parts between 5°C and 30°C, at a relative humidity of less than 70%.
2. After breaking the package seal, maintain the environment within 5°C to 25°C, at a relative humidity of less than 60%, and mount the parts within two days.
3. When storing the parts after breaking the seal, Sharp recommends storage of no longer than two weeks in a dry box or by resealing the parts in a moisture-proof bag with a desiccant.
4. When baking the parts before mounting, Sharp recommends no more than one incidence of baking, performed with the parts either temporarily mounted or on a metal tray. Do not bake the parts in the carrier tape. Bake the parts at 125°C, for 16 to 24 hours.

● Cleaning Instructions

1. Confirm this device's resistance to process chemicals before use, as certain process chemicals may affect the optical characteristics.
2. Solvent cleaning: Solvent temperature should be 45°C or below. Immersion time should be 3 minutes or less.
3. Ultrasonic cleaning: The effect upon devices varies due to cleaning bath size, ultrasonic power output, cleaning time, PCB size and device mounting circumstances. Sharp recommends testing using actual production conditions to confirm the harmlessness of the ultrasonic cleaning methods.
4. Recommended solvent materials: Ethyl alcohol, Methyl alcohol, and Isopropyl alcohol.

● Soldering Instructions

1. When using solder reflow methods, follow the time and temperature profile shown below. Sharp recommends sending parts through this process only once.

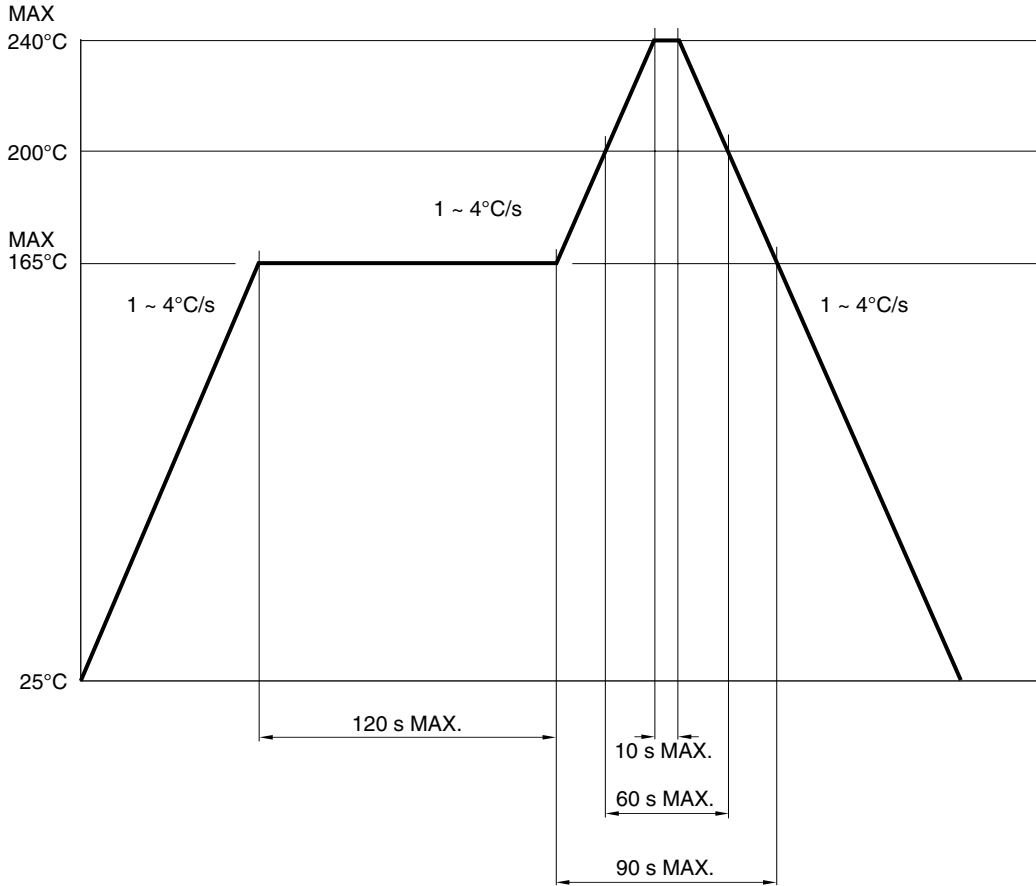

2. If using an infrared lamp to preheat the parts, such heat sources may cause localized high temperatures in the part's resin. Be sure to keep the heat profile within the guidelines shown in figure above.
3. Do not subject the package to excessive mechanical force during soldering as it may cause deformation or defects in plated connections. Internal connections may be severed due to mechanical force placed on the package due to the PCB flexing during the soldering process.
4. Sharp recommends checking the soldering process to ensure these guidelines are followed.

■ Presence of ODCs (RoHS Compliance)

This product shall not contain the following materials, and they are not used in the production process for this product:

- Regulated substances: CFCs, Halon, Carbon tetrachloride, 1,1,1-Trichloroethane (Methylchloroform). Specific brominated flame retardants such as the PBBOs and PBBs are not used in this product at all.

This product shall not contain the following materials banned in the RoHS Directive (2002/95/EC).

- Lead, Mercury, Cadmium, Hexavalent chromium, Polybrominated biphenyls (PBB), Polybrominated diphenyl ethers (PBDE).
- Content information about the six substances specified in “Management Methods for Control of Pollution Caused by Electronic Information Products Regulation” (Chinese: 电子信息产品污染控制管理办法)

Category	Toxic and Hazardous Substances					
	Lead (Pb)	mercury (Hg)	Cadmium (Cd)	Hexavalent chromiun (Cr ⁶⁺)	Polybrominated biphenyls (PBB)	Polybrominated diphenyl ethers (PBDE)
Infrared Emitting Diode	✓	✓	✓	✓	✓	✓

NOTE: ✓ indicates that the content of the toxic and hazardous substance in all the homogeneous materials of the part is below the concentration limit requirement as described in SJ/T 11363-2006 standard.

■ Important Notices

· The circuit application examples in this publication are provided to explain representative applications of SHARP devices and are not intended to guarantee any circuit design or license any intellectual property rights. SHARP takes no responsibility for any problems related to any intellectual property right of a third party resulting from the use of SHARP's devices.

· Contact SHARP in order to obtain the latest device specification sheets before using any SHARP device. SHARP reserves the right to make changes in the specifications, characteristics, data materials, structure, and other contents described herein at any time without notice in order to improve design or reliability. Manufacturing locations are also subject to change without notice.

· Observe the following points when using any devices in this publication. SHARP takes no responsibility for damage caused by improper use of the devices which does not meet the conditions and absolute maximum ratings to be used specified in the relevant specification sheet nor meet the following conditions:

(i) The devices in this publication are designed for use in general electronic equipment designs such as:

- Personal computers
- Office automation equipment
- Telecommunication equipment (terminal)
- Test and measurement equipment
- Industrial control
- Audio visual equipment
- Consumer electronics

(ii) Measures such as fail-safe function and redundant design should be taken to ensure reliability and safety when SHARP devices are used for or in connection with equipment that requires higher reliability such as:

- Transportation control and safety equipment (i.e., aircraft, trains, automobiles, etc.)
- Traffic signals
- Gas leakage sensor breakers
- Alarm equipment
- Various safety devices, etc.

(iii) SHARP devices shall not be used for or in connection with equipment that requires an extremely high level of reliability and safety such as:

- Space applications
- Telecommunication equipment (trunk lines)
- Nuclear power control equipment
- Medical and other life support equipment (e.g. scuba)

· If the SHARP devices listed in this publication fall within the scope of strategic products described in the Foreign Exchange and Foreign Trade Law of Japan, it is necessary to obtain approval to export such SHARP devices.

· This publication is the proprietary product of SHARP and is copyrighted, with all rights reserved. Under the copyright laws, no part of this publication may be reproduced or transmitted in any form or by any means, electronic or mechanical, for any purpose, in whole or in part, without the express written permission of SHARP. Express written permission is also required before any use of this publication may be made by a third party.

· Contact and consult with a SHARP representative if there are any questions about the contents of this publication.